



Main Features

- ♦ 8" LCD (VGA with LED backlight) with 5-wires resistive touch screen
- ♦ Daylight Readable Display
- ♦ Intel® Atom™ N450 1.6GHz processor
- ♦ Fully rugged MIL-STD810F and IP54
- ♦ Drop resistant from a height of 4 feet
- ♦ Wireless connectivity of WLAN/WWAN/Bluetooth
- ♦ Wireless LAN support WiFi 802.11 b/g/n
- ♦ WWAN support GSM/GPRS/HSDPA/WCDMA (optional)
- ♦ Integrated GPS module support RF passing through to external connector over cradle
- ♦ Integrated Laser Barcode Scanner (1D/2D) or HF type RFID (optional)
- ♦ Integrated 2M pixel Camera in rear or in front bezel (optional)
- ♦ 1 x Navigation key and 4 x Programmable function Key
- ♦ Battery life sustains for over 4-6 hours

Product Overview

Featuring a 8" TFT display, MRC 2200/2300 introduces LED backlight TFT technology to get better power consumption while adapts a more reliable 5 wire touch screen which provides outstanding endurance and faster response time. The new battery design for MRC 2200/2300 provides a hot swappable feature to be working more efficiency. With the powerful 3.5G mobile broadband engine, the MRC 2200/2300 can benefit users by efficiently utilizing existing broadband service coverage. A thoughtful design of front panel of MRC 2200/2300 provides a option of front-side colorful camera from 0.3M pixel to 2M pixel. The MRC 2200/2300 is equipped with a built-in barcode scanner and RFID interface, providing various accessories to match your application and business requirement. On board GPS and daylight readable LCD make the MRC 2300 ideal for outdoor application. The MRC 2200/2300 goes through rigorous testing such as the MIL-STD-810F and IP54 to ensure that it can stand harsh environment and meet the industrial standard of reliability.

The highly reliable and rugged MRC 2200/2300 series support mobile data transition in the field in multiple sectors, including transportation, field service, portable payment, store picking and distribution. It can increase worker efficiency and save the total cost of in-field data management.

Specifications

CPU Support

- ♦ Intel® Atom™ N450 1.6GHz processor 667MHz FSB

Chipset

- ♦ Intel® System Controller Hub ICH8M

Main Memory

- ♦ 1GB DDR2 SDRAM- 667MHz, support up to 2GB (optional)

Storage

- ♦ 8GB Solid State Drive/SATA interface, support up to 64GB or 120GB 1.8" HDD/SATA interface

Audio

- ♦ Intel® high definition audio
- ♦ AC '97 Compatible
- ♦ 2 x 2W built-in speakers
- ♦ 1 x external Mic-in and 1 x external Line-out
- ♦ 1 x Internal Microphone

Display

- ♦ 8" TFT LCD with LED backlight, 800 x 600 pixels (SVGA)
- ♦ 5-wires resistant touch screen

- ♦ Daylight readable display
- ♦ Build-in ambient light sensor to adjust LCD brightness

I/O

- ♦ 3 x External USB 2.0 port (1 x mini USB connector, 2 x USB connector)
- ♦ 1 x Mic-in
- ♦ 1 x Line-out
- ♦ 1 x 2M pixel CMOS camera
- ♦ 1 x 19V DC power input
- ♦ 1 x Docking connector

Communication

- ♦ 1 x Class 2 Bluetooth Module V 2.1 + EDR
- ♦ 1 x WiFi Module (802.11 b/g/n)
- ♦ 1 x GPS Module
- ♦ 1 x Mobile broadband Module, support GSM/GPRS/HSDPA/WCDMA (optional)
- ♦ 1 x RFID Module, 13.56MHz, support Tag of ISO1443A or ISO15693 (optional)
- ♦ 1 x Barcode scanner, 1D/2D (optional)

Dimension Drawing

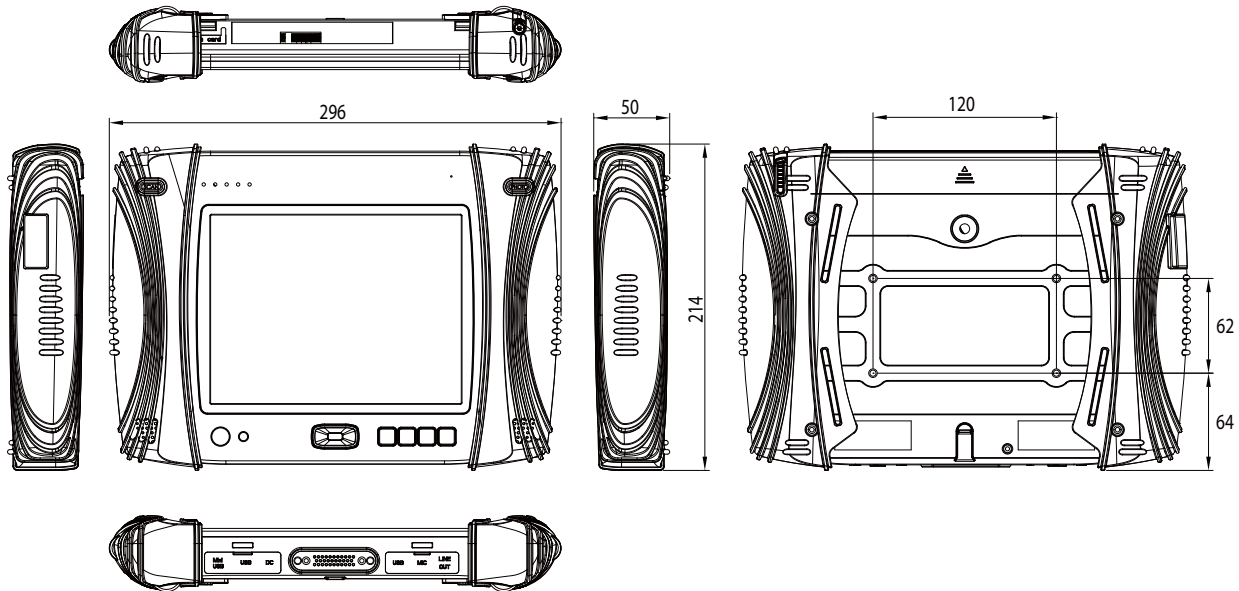

Indicators and Buttons

- Power on/off Status (Blue LED on power switch)
- Battery Status (Green LED: Battery Discharged/Glows Orange: charging/fully charged: Battery LED turn off)
- Battery Low (Battery LED: Glows Green and Power LED Glows Blue)
- Wireless on/off LED (Orange LED on Wireless on/off switch ,Glows Orange is being accessed)
- Hard Drive Status (Green LED: Glows Green HDD is being accessed)
- 4 x Programmable function keys
- Navigation key
- Power on/off switch
- Wireless on/off switch
- Camera snap shot button
- Barcode scanner button

Power Input

- Power Input Voltage: DC 19V/3.42A
- AC Adapter: 100V-240V AC, 50Hz/60Hz
- Battery: Rechargeable 3 Cell (3S1P) Lithium Ion Smart Battery Pack (2600 mAh@11.1V, 28.86Wh) Hot Swappable
- Over Charge Protection, Over Discharge Protection, Over Current and Output Short

Dimensions

- 296mm (W) x 214mm (H) x 50mm (D) with Rubber
- 280mm (W) x 205mm (H) x 37mm (D) without Rubber
- Weight: 1.44Kg with Rubber; 1.2Kg without Rubber

Construction

- Plastic – upper and lower housing (ABS + PC)
- Color: Black

Environment

- **Operating Temperature: -20°C to 50°C**
Tested MIL-STD-810F methods 501.4, 502.4
- **Storage Temperature: -30°C to 60°C**
Tested MIL-STD-810F methods 501.4, 502.4
- **Thermal Shock: -20°C to 50°C**
Tested MIL-STD-810F method 503.4
- **Rel. Humidity: 0% to 95%**
Tested MIL-STD-810F method 507.4
- **Vibration 5G PTP at 5-500Hz**
Tested MIL-STD-810F method 514.5C-3 (Highway truck)
- **Transit Shock: 4 feet drop, polywood, all surfaces, edges and corners (26drops)**
Tested MIL-STD-810F method 516.5
- **Mechanical Shock: 20g, 11ms, Terminal Sawtooth, Operating 40g, 11ms, Terminal Sawtooth, Non-Operating**
Tested MIL-STD-810F method 516.5
- **Crash Shock: 75g, 11ms, Terminal Sawtooth**
Tested MIL-STD-810F method 516.5
- **Rain: Drip Proof, 7 gal/ft²/hr**
- **Compliance: MIL-STD-810F and IP54**

Certifications

- CE approval
- FCC Class B

Ordering Information

- ♦ **MRC 2300-H (P/N: 10U00230000X0)**
8" Fanless Ruggedized Tablet PC
with Intel® Atom™ 1.6GHz Processor/120GB HDD/1GB Memory/
Daylight Readable
Touch Screen/GPS/WiFi/Bluetooth
- ♦ **MRC 2300-S (P/N: 10U00230001X0)**
8" Fanless Ruggedized Tablet PC
with Intel® Atom™ 1.6GHz Processor/8GB SSD/1GB Memory/
Daylight Readable
Touch Screen/GPS/WiFi/Bluetooth
- ♦ **Optional Accessory Ordering Information for MRC 2100**
Vehicle Docking Station (P/N: 10UK0DOCK00X0)
Desktop Docking Station (P/N: 10UK0DOCK02X0)
Holding Bracket (P/N: 50501A0325X00)
4 slots Battery Charger (P/N: 10UK0BATT00X0)
1D Laser Barcode Scanner: RIOTEC (P/N: 88U00220001X0)
2D Laser Barcode Scanner: Opticon (P/N: 88U00220003X0)
HSDPA Mobile Card Pack w/ Antenna: Sierra MC8790V (P/N: 88U00210006X0)
RFID Module: HF type 13.56MHz (P/N: 88U00220002X0)
Carry Case (P/N: 6019900015X00)
Spare Battery Pack (3S1P) (P/N: 4ZTSS26301X00)
Vehicle Cigarette Adaptor Charger (P/N: 7400065007X00)
USB to VGA Adaptor (P/N: 7500VGA004X00)
USB to Giga LAN Adaptor (P/N: 7500LAN005X00)
Windows XP Pro for Embedded Software Kit (P/N: 88U00220004X0)
Windows XP Embedded Software Kit (P/N: 88U00220005X0)
Power Cable (US) (P/N: 60233POW38X00)
Power Cable (EU) (P/N: 60233POW39X00)
Power Cable (UK) (P/N: 60233POW40X00)



Desktop Docking Station



Vehicle Docking Station



Holding Bracket



4 Slots Battery Charger



Carry Case



Spare Battery Pack (3S1P)



Vehicle Cigarette Adaptor Charger



USB to VGA Adaptor



USB to Giga Lan Adaptor



Contact
sales@rm-systems.co.uk
0845 652 0816

Rugged Mobile Systems
Sandbach Enterprise Centre
Wesley Avenue
Sandbach
Cheshire
CW11 1DG